

# voltbricks

## DATASHEET

# VDV Series

## VDV80

Multi-purpose compact DC/DC converters



## Description

**Compact isolated DC/DC converters of VDV Series** for industrial and special purpose applications. Despite the small size (84,5×52,7×12,85 mm) the maximum output power of modules reach up 80 W and they are able to operate in a wide case operating temperature range (–60...+125°C). These modules might have single galvanically isolated output, remote on/off, short circuit, overcurrent and thermal protection and can operate in series modes. Without optocouplers in the converter's circuit it can safely operate in conditions of ionizing radiation and high temperature. Power supplies have variable protections from different factors: vibration, dirt, moisture fog and salt fog.

These modules undergo special thermal and limit test including burn-in test with extreme on/off modes.

## Compliance

- MIL-STD-810G
- MIL-STD-461F (CE102)
- MIL-STD-704E



Description of VDV Series on the manufacturer's website  
<https://voltbricks.com/product/vdv>

## Features

- 5 year warranty
- Output current up to 16 A
- 28 VDC (index "V") input compliant with MIL-STD-704E
- Low-profile design (12,85 mm) with cylindrical pin outs
- Case operating temperature –60...+125°C
- 125 °C baseplate operation without derating
- Magnetic feedback without optocouplers
- Short circuit protection, overvoltage, thermal protection
- Remote on/off
- Output voltage adjustment
- Typical efficiency 88% (Uout.=24 VDC)
- Polymer potting sealing

### Order registration

+65 6950 0011, Global Operations Team

### Technical support

[support@voltbricks.com](mailto:support@voltbricks.com)

### Reliability test

[https://support.voltbricks.com/Reliability-Test\\_ENG.pdf](https://support.voltbricks.com/Reliability-Test_ENG.pdf)

### 3D model

<https://support.voltbricks.com/models/VDV80-en.stp>

## Ordering information

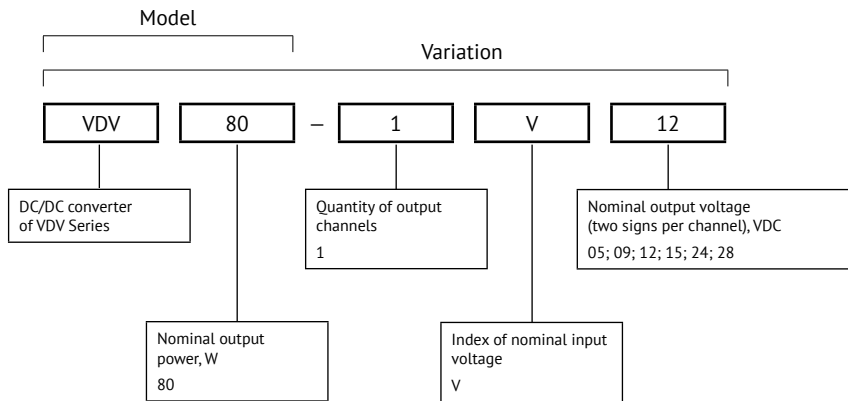

For more information please contact  
 our Global Operations Team

+65 6950 0011  
[info@voltbricks.com](mailto:info@voltbricks.com)

### Output power and current

Output power, W	80					
Output voltage, VDC	5	9	12	15	24	28
Maximal output current, A	16	8,88	6,7	5,3	3,33	2,85

Other output voltage within range 3...70 VDC is also available upon special request.

### Index of nominal input voltage\*

Parameter	Index "V"
Nominal input voltage, VDC	28
Input voltage range, VDC	17...36
Transient deviation (1 s), VDC	17...80
Typical efficiency for Uout.=24 VDC	88%

\* Reflected input ripple current (10-10000 Hz) – 8% Uin. nom

## Specifications

All specifications valid for normal climatic conditions (ambient temp. 15...35°C; relative humidity 45...80%; air pressure 8,6×10<sup>4</sup>...10,6×10<sup>4</sup> Pa), U<sub>in</sub>. nom, I<sub>out</sub>. nom, unless otherwise stated. It is important to note that the information herein is not full.

### Output specifications

Parameter		Value
Output voltage adjustment of single channel models		±5% U <sub>out</sub> . nom
Regulation	Input voltage variation (U <sub>min</sub> ...U <sub>max</sub> )	max ±2% U <sub>out</sub> . nom
	Load variation (10...100% I <sub>max</sub> )	
	Total regulation	±6% U <sub>out</sub> . nom
Ripple and noise (p-p)		<2% U <sub>out</sub> . nom
Maximum capacitive load	5 VDC	5100 uF
	12 VDC	400 uF
	24 VDC	75 uF
Start up time (remote)		max 0,1 s
Overload protection level*		<2,2 P <sub>max</sub>
Short circuit protection*		hiccup auto recovery
Overvoltage protection		1,5 U <sub>nom</sub>
Trancient responce deviation		see fig. 8 (d)

\* Parameters are stated for the information purposes and could not be used at long term work, exceeding maximum output current, at work outside of a range of operating temperatures.

### General specifications

Parameter		Value
Case temperature	Operating	-60...+125°C
	Storage	-60...+125°C
Switching frequency		130 kHz ±10%
Isolation capacitance	input/output	1500 pF
Isolation voltage (60 s)	input/output, input/case, output/case	500 VAC, 50 Hz
Isolation resistance @ 500 VDC	input/output, input/case, output/case	20 MOhm min, normal climatic conditions
Thermal impedance		5,3°C/W
Thermal protection level		118...125°C, clamp, auto recovery
Remote on/off		Off.: connection of pins "ON" and "-IN", I <sub>l</sub> ≤5 mA
Vibration and dust proof, salt fog resistant		+
Moisture proof (T <sub>amb</sub> .=25°C)		98%
Typical MTBF		1 737 900 hrs
Failure rate		<0,05%
Warranty		5 years

## Specifications (cont.)

### Physical specifications

Parameter	Value
Case material	aluminium
Potting	epoxy polimer
Pin material	phosphor bronze, SnPb plated
Weight	max 110 g
Soldering temperature	260°C @ 5 s

### Design topology

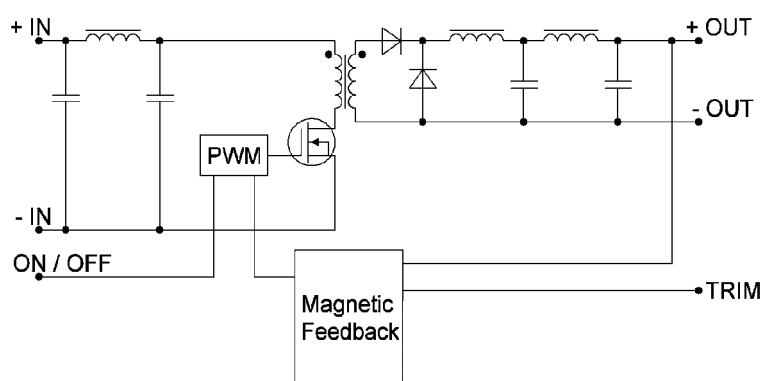

Figure 1. Design topology.

## Service functions

### Typical connection

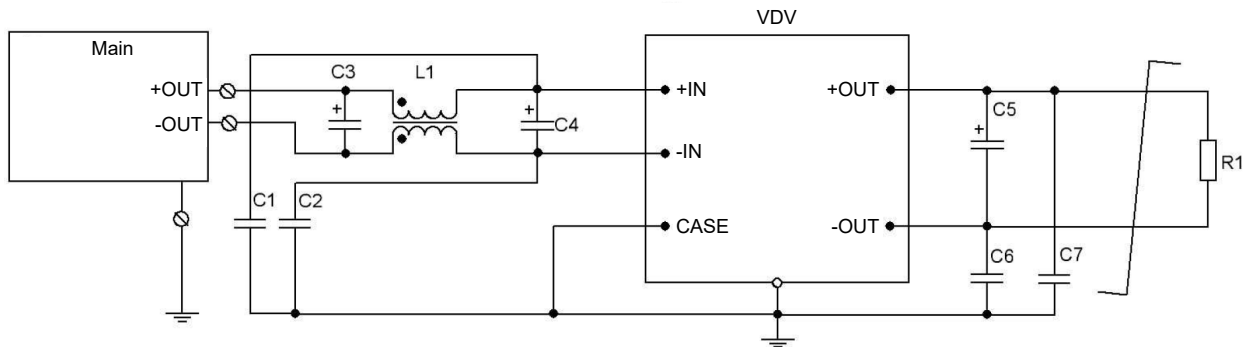

Figure 2 (a). Typical connection for a single-channel module.

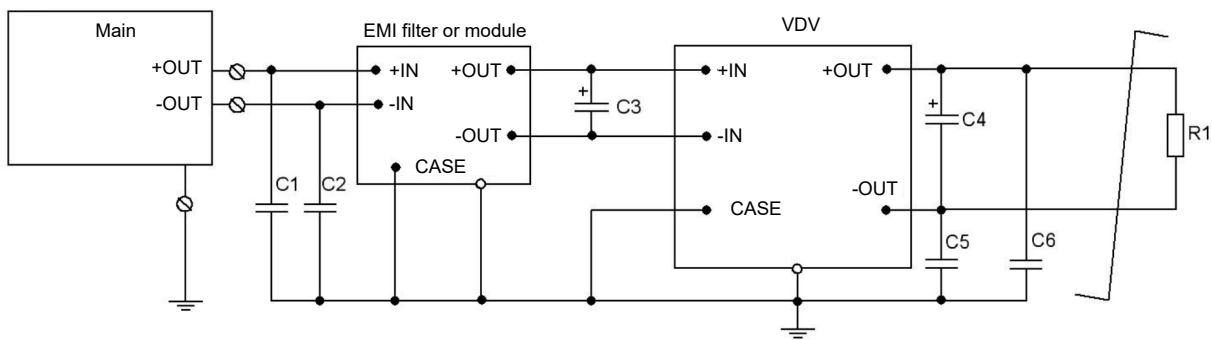

Figure 2 (b). Typical connection with filtration unit.

C1, C2, C6, C7		ceramic capacitor		100...4700 pF 500 VDC min
C4		tantalum capacitor	Input voltage	68 – 150 uF
C5		tantalum capacitor	Output voltage	5 VDC 1275 uF 12 VDC 100 uF 24 VDC 25 uF
EMI Filter	L1	common mode choke		0,7 mH
	C3	ceramic capacitor	Input voltage	68 – 150 uF
EMI Module	VFA series	Double Pi filter EMI module. See datasheet VFA Series	Maximum current up to 20 A, overvoltage and surge protection, loss insertion up to 60 db	

## Service functions (cont.)

### Remote control

Function of remote control by a signal allows to control the unit's operation using mechanical relay or electric switch of "open collector" type.

The unit should be powered off by connecting "ON" output to "-IN" output. The switch can carry current of up to 5 mA, the max voltage drop on the switch should be less than 1,1 V.

The unit is powered on by disconnecting the switch within the time less then 5  $\mu$ s. Being disconnected the switch is applied by approximately 5 V, allowable current leakage through the switch should not be over 50  $\mu$ A.

To arrange remote power off/on of several units simultaneously it is not allowed to use additional elements in the circuit to connect outputs "ON" and "-IN" and a switch.

If the function of remote power off/on is not used, "ON" output is allowed to be left unconnected.

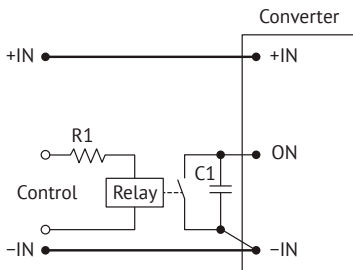

Figure 3 (a). ON/OFF control by relay.

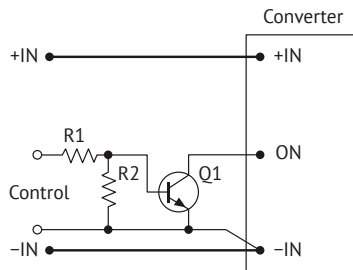

Figure 3 (b). ON/OFF control by bipolar transistor.

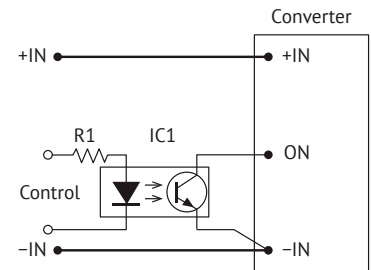

Figure 3 (c). ON/OFF control by optocoupler.

### Adjustment

Adjustment of output voltage of a power supply unit within the range of at least  $\pm 5\%$  can be done by connecting "ADJ" output (if available) through "-OUT" output to increase output voltage, or through "+OUT" output to decrease the output voltage.

In case of using variable resistor Rvar and outside resistors (R1, R2) it is possible to fulfill the adjustment both to increase and decrease the output voltage.

If you need to control the output voltage of a power supply unit by a signal from external source of current or voltage, e.g. in micro-controller automated control systems using DAC, the external current or voltage signal should be supplied to the adjustment output relating to "-OUT" output, as shown in the drawings (e) and (d).

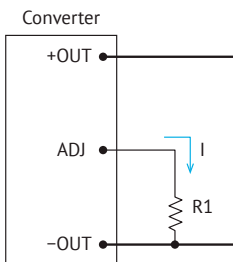

Figure 4 (a). Output voltage increase.

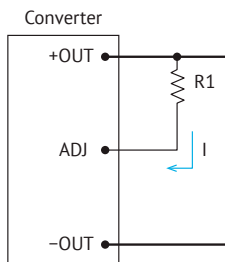

Figure 4 (b). Output voltage decrease.

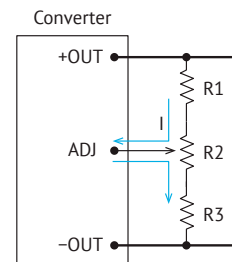

Figure 4 (c). Adjustment by resistive divider.

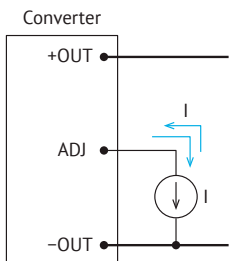

Figure 4 (e). Adjustment by current source.

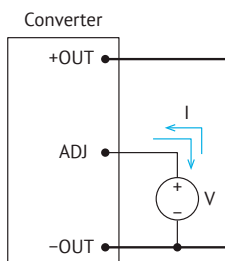

Figure 4 (d). Adjustment by voltage source.

## Service functions (cont.)

### Output voltage VS resistor rating

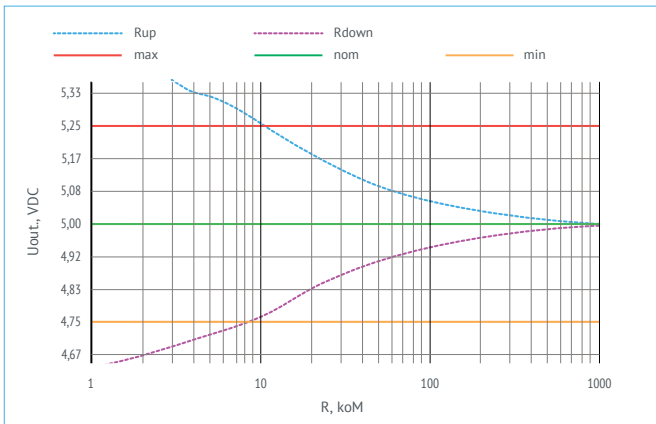

Figure 5 (a). Current and voltage values for adjustment of  $U_{out}=5$  VDC.

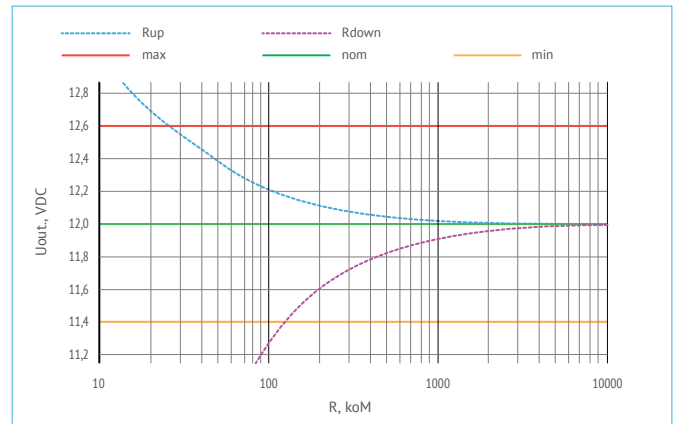

Figure 5 (b). Current and voltage values for adjustment of  $U_{out}=12$  VDC.

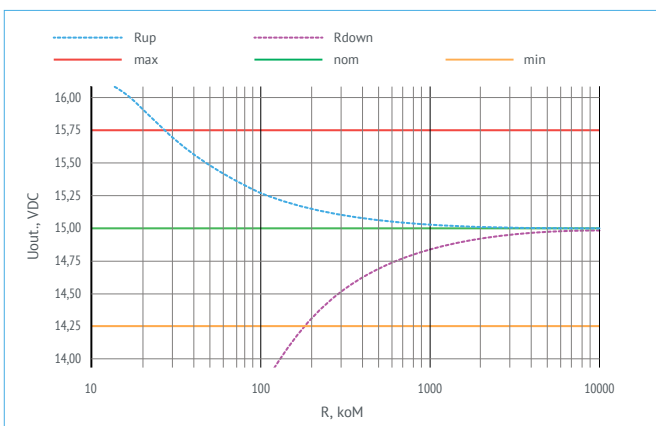

Figure 5 (c). Current and voltage values for adjustment of  $U_{out}=15$  VDC.

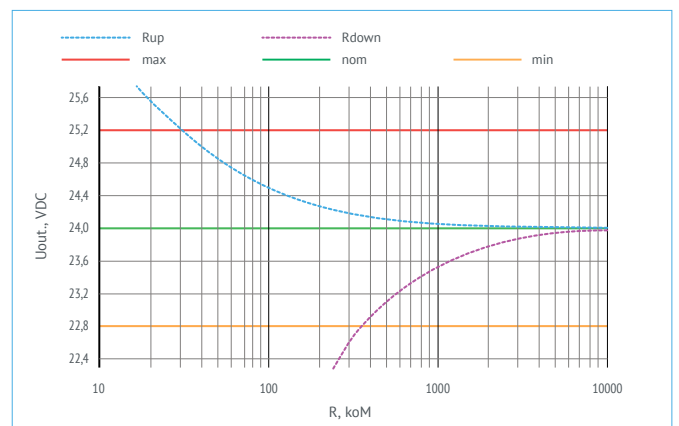

Figure 5 (d). Current and voltage values for adjustment of  $U_{out}=24$  VDC.

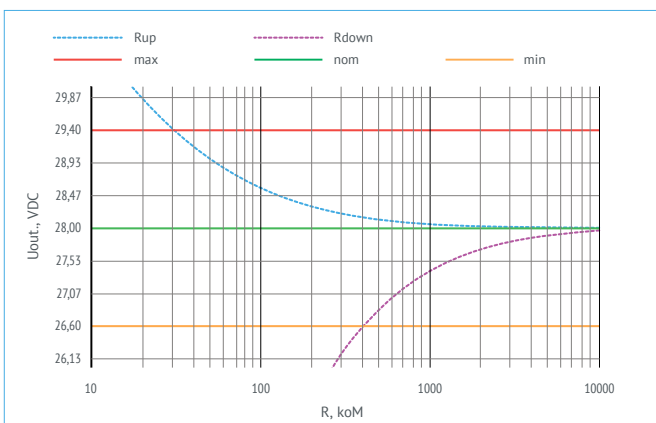
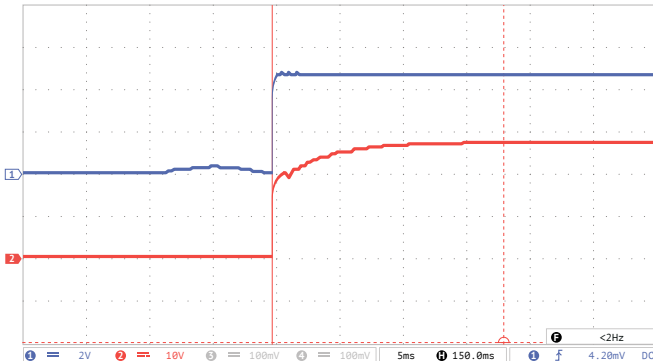

Figure 5 (e). Current and voltage values for adjustment of  $U_{out}=28$  VDC.

## Oscillograph charts

Testing conditions  $U_{in}=28$  VDC,  $I_{out}=6,6$  A,  $T_{amb}=25^{\circ}\text{C}$ ,  $U_{out}=12$  VDC,  $C_{out}=100$   $\mu\text{F}$

The database of regulated parameters of the manufactured products is available. Pls. contact your personal manager or customer support service to get necessary information.

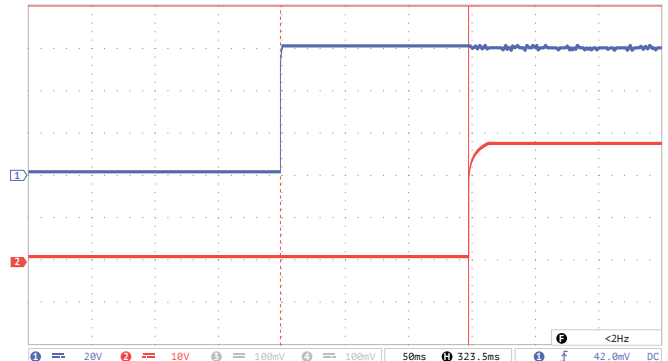

**Figure 6 (a).** Oscillograph chart of setting output voltage after supplying remote control signal to ON-output.

Ray 1 (blue) – voltage at ON-output. Scale 2 V/div.

Ray 2 (red) – output voltage. Scale 10 V/div.

Time scale  $t=5$  ms/div.

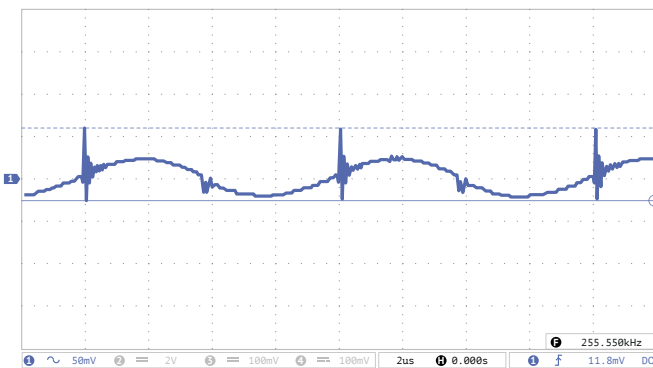

**Figure 6 (b).** Oscillograph chart of output voltage after supplying the input voltage.

Ray 1 (blue) – input voltage. Scale 20 V/div.

Ray 2 (red) – output voltage. Scale 10 V/div.

Time scale  $t=50$  ms/div.



**Figure 6 (c).** Oscillograph chart of output voltage ripple.

Ray 1 (blue) – ripple of output voltage. Scale 50 mV/div.

Time scale 2  $\mu\text{s}$ /div.

Measuring technique: see Electrical Test Screen.



**Figure 6 (d).** Oscillograph chart of voltage transient deviation during load “drop/rise”.

Ray 1 (blue) - output voltage. Scale 2 V/div.

Time scale  $t=5$  ms/div.

Modes:

- “drop” output current variation (10..100%)  $I_{nom}$ ;
- “rise” output current variation (10..100%)  $I_{nom}$ ;
- build-up time 500  $\mu\text{s}$ .



## Noise spectrogram

Testing according to MIL-STD-461F CE102. (Tcase=25°C, Vin.=+12 V, full load, unless otherwise specified)

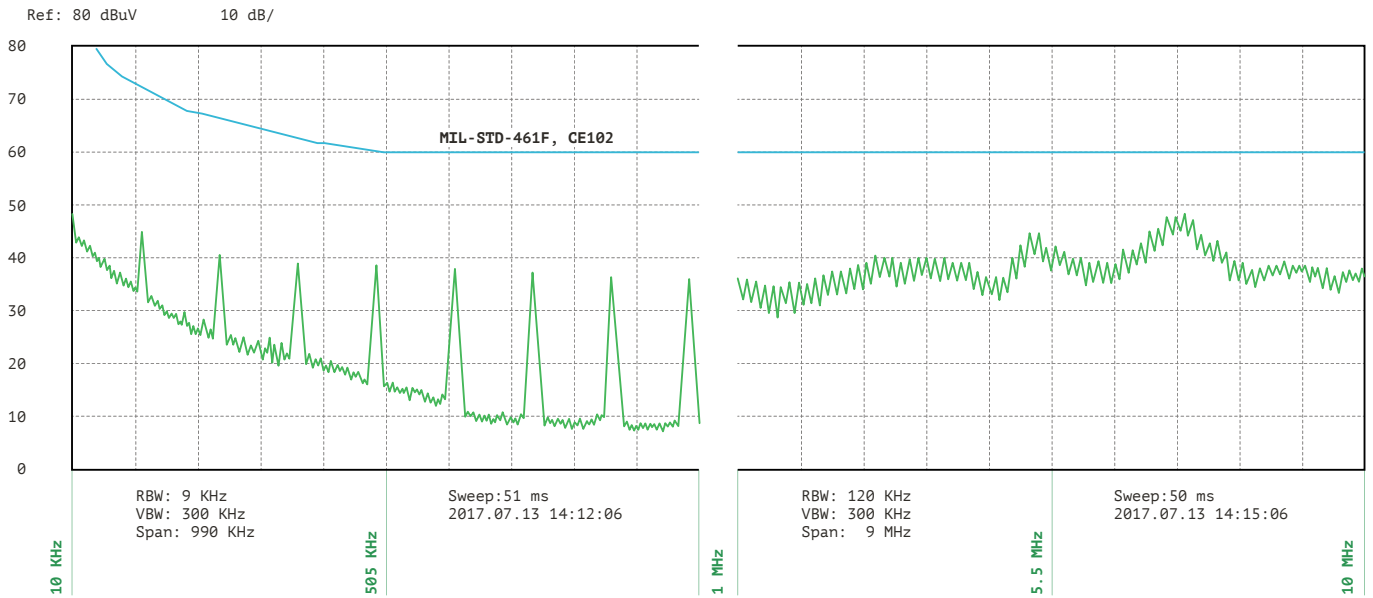

Figure 7. Spectrogram of VDV80-1V05 with typical connection diagram.

## Outline dimensions

### Models packed in reinforced case with flanges

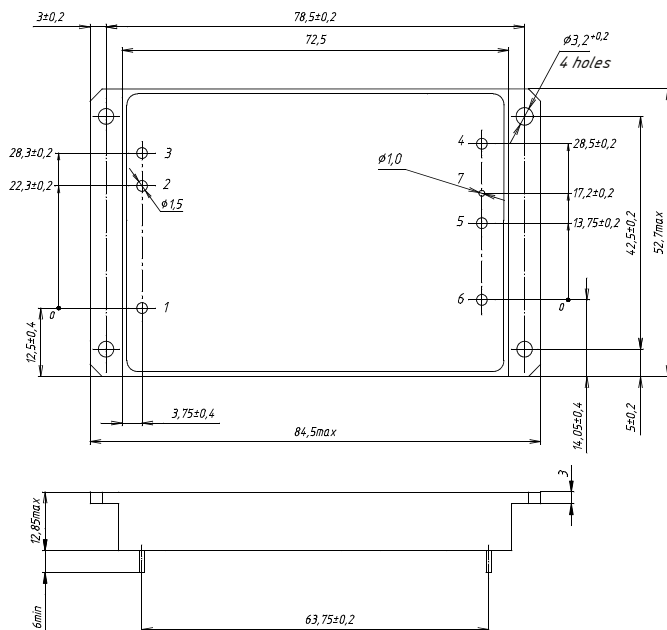

Figure 8. Single-output models.

### Pin out

Pin #	1	2	3	4	5	6	7
Function	+IN	-IN	ON	CASE	+OUT	-OUT	TRIM

## Heatsink

Part number	Ribs configuration	Dimensions A×B×H×D, mm	Area, cm <sup>2</sup>	Weight, g
752695.006	Longitudinal	84,5×52×14×4	218	90
752695.006-01	Longitudinal	84,5×52×24×4	383	

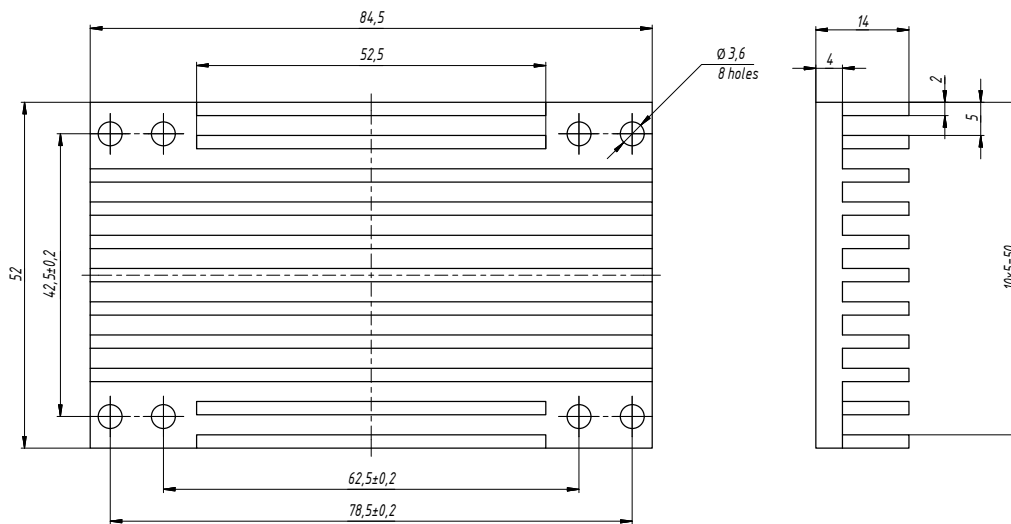

Figure 9 (a). 752695.006.

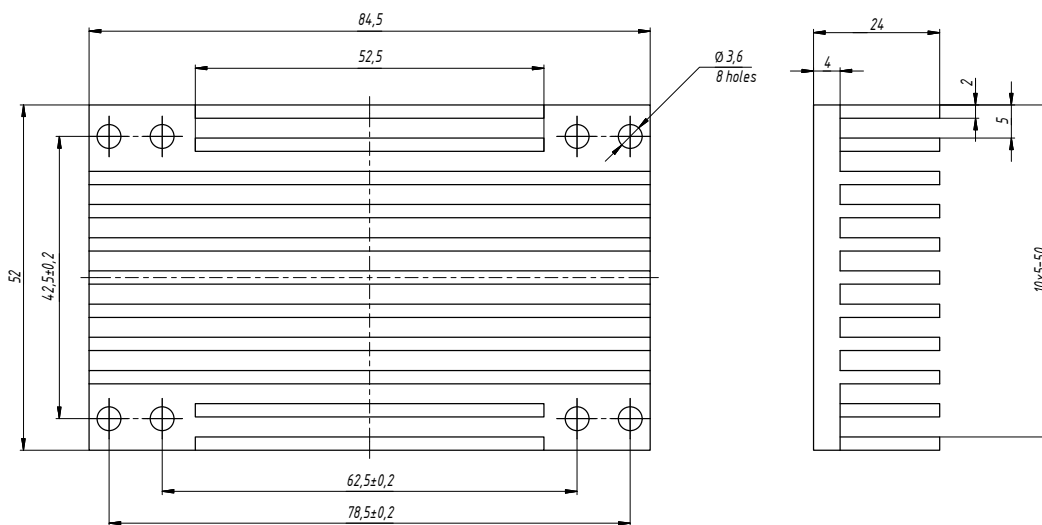

Figure 9 (b). 752695.006-01.

# voltbricks

[www.voltbricks.com](http://www.voltbricks.com) [info@voltbricks.com](mailto:info@voltbricks.com)

VOLTBRICKS PTE. LTD.

105 Cecil street

#15-01 The OCTAGONE

Singapore 069534

+65 6950 0011

Manufacturer of reliable DC/DC converters and power supply systems

This datasheet is valid for the following units: VDV80-1V05; VDV80-1V09; VDV80-1V12; VDV80-1V15; VDV80-1V24; VDV80-1V28.