

voltbricks

DATASHEET

VDV Series

VDV3, VDV5, VDV8

Multi-purpose compact DC/DC converters

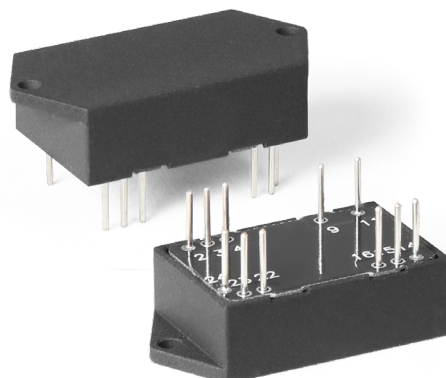

Description

Compact isolated DC/DC converters of VDV Series for industrial and special purpose applications. Despite the small size (40×20,2×10,15 mm) the maximum output power of modules reach up 8 W and they are able to operate in a wide case operating temperature range (–60...+125°C). These modules might have single or dual galvanically isolated output, remote on/off, short circuit, overcurrent and thermal protection and can operate in series modes. Without optocouplers in the converter's circuit it can safely operate in conditions of ionizing radiation and high temperature. Power supplies have variable protections from different factors: vibration, dirt, moisture fog and salt fog.

These modules undergo special thermal and limit test including burn-in test with extreme on/off modes.

Compliance

- MIL-STD-810G
- MIL-STD-461F (CE102)
- MIL-STD-704A-F



Description of VDV Series on the manufacturer's website
<https://voltbricks.com/product/vdv>

Features

- 5 year warranty
- Output current up to 1,6 A
- 28 VDC input compliant with MIL-STD-704A-F (except Cat. C)
- Low-profile design (10,15 mm) with cylindrical pin outs
- Case operating temperature –60...+125°C
- 125 °C baseplate operation without derating
- Magnetic feedback without optocouplers
- Single and dual output models
- Short circuit protection, overvoltage, thermal protection
- Remote on/off
- Output voltage adjustment
- Typical efficiency 82% (Uout.=24 VDC)
- Polymer potting sealing

Order registration

+65 6950 0011 Global Operations Team

Technical support

support@voltbricks.com

Reliability test

https://support.voltbricks.com/Reliability-Test_ENG.pdf

Ordering information

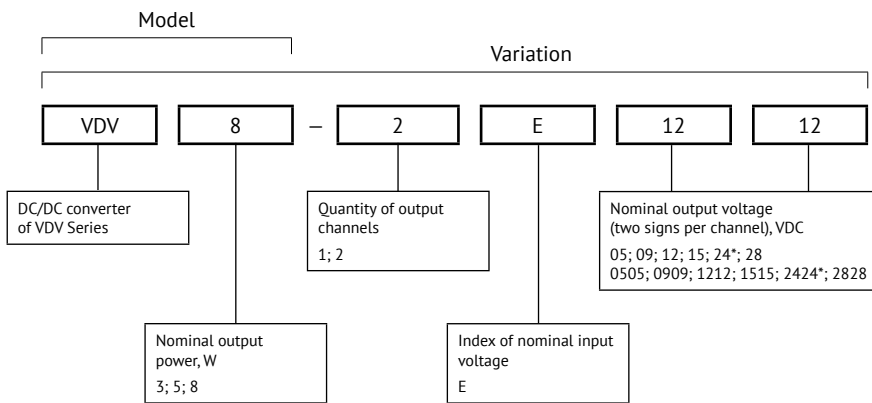

For more information please contact our Global Operations Team

+65 6950 0011

info@voltbricks.com

* Except for VDV8

Output power and current

Output power, W	3						5						8				
Output voltage, VDC	5	9	12	15	24	28	5	9	12	15	24	28	5	9	12	15	28
Maximal output current, A	0,6	0,33	0,25	0,2	0,13	0,11	1	0,55	0,42	0,33	0,21	0,18	1,6	0,88	0,67	0,53	0,28

Other output voltage within range 3...70 VDC is also available upon special request.

Index of nominal input voltage**

Parameter	Index "E"
Nominal input voltage, VDC	28
Input voltage range, VDC	9...70
Transient deviation, VDC	1 s 10 s
Typical efficiency for Uout.=24 VDC	81%

** Reflected input ripple current (10–10000 Hz) – 8% Uin. nom

Specifications

All specifications valid for normal climatic conditions (ambient temp. 15...35°C; relative humidity 45...80%; air pressure 8,6*10⁴...10,6*10⁴ Pa), U_{in}. nom, I_{out}. nom, unless otherwise stated. It is important to note that the information herein is not full.

Output specifications

Parameter		Value
Output voltage adjustment of single channel models		±5% U _{out} . nom
Regulation	Input voltage variation (U _{min} ...U _{max})	±2% U _{out} . nom (for the 1st output channel) ±7% U _{out} . nom (for the 2nd output channel)
	Load variation (10...100% I _{max})	±12% U _{out} . nom (for the 2nd output channel) for dual-channel version with voltage difference between channels ≥20%
	Total regulation	±6% U _{out} . nom (for the 1st output channel) ±10% U _{out} . nom (for the 2nd output channel) ±14% U _{out} . nom (for the 2nd output channel) for dual-channel version with voltage difference between channels ≥20%
Ripple and noise (p-p)		<2% U _{out} . nom
Maximum capacitive load	5 VDC	500 uF
	12 VDC	50 uF
	24 VDC	20 uF
Start up time (remote)		max 0,1 s
Overload protection level*	3 W	<4,3 P _{max}
	5 W	<2,7 P _{max}
	8 W	<1,8 P _{max}
Short circuit protection*		hiccup auto recovery
Overvoltage protection		1,5 U _{nom}
Trancient response deviation		see fig. 8 (d)

* Parameters are stated for the information purposes and could not be used at long term work, exceeding maximum output current, at work outside of a range of operating temperatures.

Specifications (cont.)

General specifications

Parameter		Value
Case temperature	Operating	-60...+125°C
	Storage	-60...+125°C
Switching frequency		300 kHz ±10%
Isolation capacitance	input/output	1500 pF
Isolation voltage (60 s)	input/output, input/case, output/case	500 VAC, 50 Hz
Isolation resistance @ 500 VDC	input/output, input/case, output/case	20 MOhm min, normal climatic conditions
Thermal impedance		19,8°C/W
Thermal protection level		118...125°C, clamp, auto recovery
Remote on/off		Off.: connection of pins "ON" and "- IN", I _s ≤ 5 mA
Vibration and dust proof, salt fog resistant		+
Moisture proof (T _{amb.} =25°C)		98%
Typical MTBF		1 737 900 hrs
Failure rate		<0,05%
Warranty		5 years

Physical specifications

Parameter	Value
Case material	aluminium
Potting	epoxy polimer
Pin material	phosphor bronze, SnPb plated
Weight	max 22 g
Soldering temperature	260°C @ 5 s

Design topology

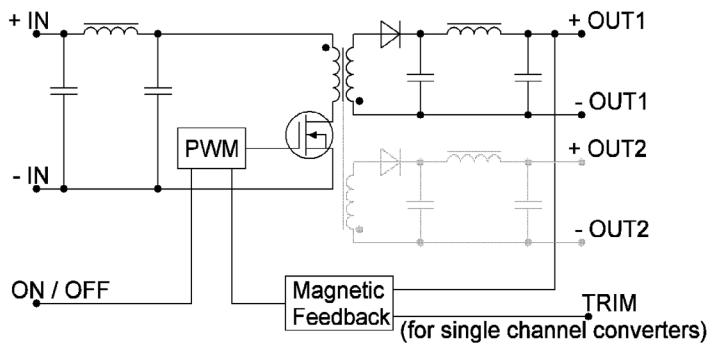

Figure 1. Design topology.

Service functions

Typical connection

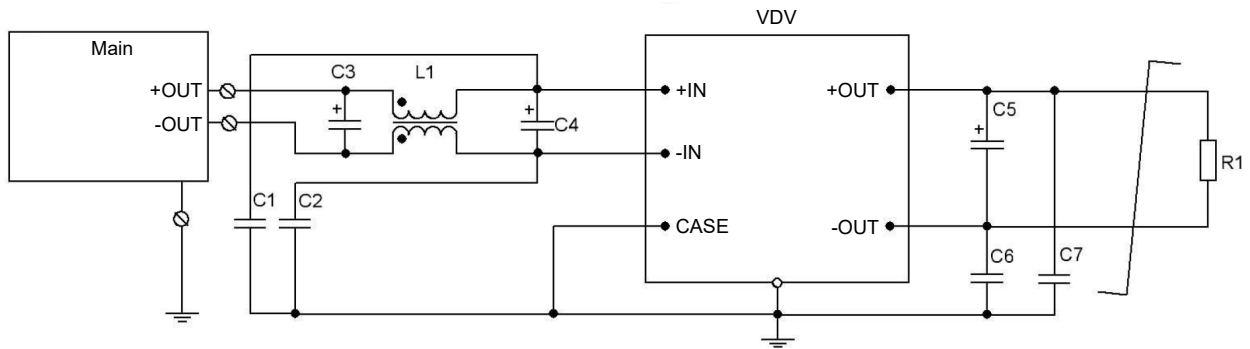

Figure 2 (a). Typical connection for a single-channel module.

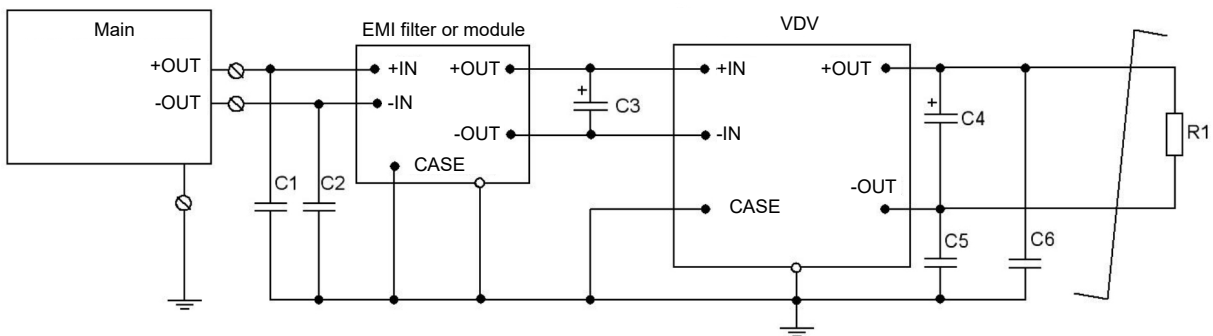

Figure 2 (b). Typical connection with filtration unit.

C1, C2, C6, C7		ceramic capacitor		100...4700 pF 500 VDC min
C4		tantalum capacitor	Input voltage	3,3–15 uF 100 V
C5		tantalum capacitor	Output voltage	5 VDC 250 uF 12 VDC 25 uF 24 VDC 10 uF
EMI Filter	L1	common mode choke		1 mH
	C3	ceramic capacitor	Input voltage	3,3–15 uF 100 V
EMI Module	VFA series	Double Pi filter EMI module. See datasheet VFA Series	Maximum current up to 20 A, overvoltage and surge protection up to 60 db	

Service functions (cont.)

Remote control

Function of remote control by a signal allows to control the unit's operation using mechanical relay or electric switch of "open collector" type.

The unit should be powered off by connecting "ON" output to "-IN" output. The switch can carry current of up to 5 mA, the max voltage drop on the switch should be less than 1,1 V.

The unit is powered on by disconnecting the switch within the time less then 5 μ s. Being disconnected the switch is applied by approximately 5 V, allowable current leakage through the switch should not be over 50 μ A.

To arrange remote power off/on of several units simultaneously it is not allowed to use additional elements in the circuit to connect outputs "ON" and "-IN" and a switch.

If the function of remote power off/on is not used, "ON" output is allowed to be left unconnected.

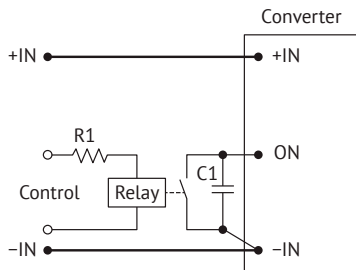

Figure 3 (a). ON/OFF control by relay.

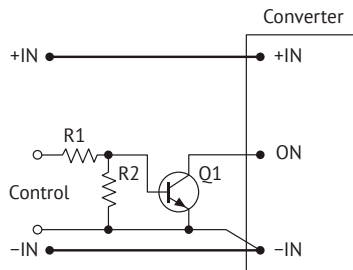

Figure 3 (b). ON/OFF control by bipolar transistor.

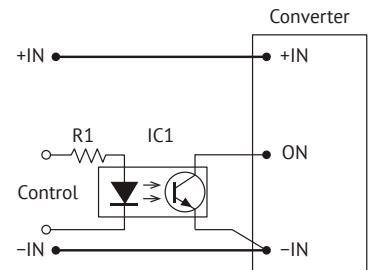

Figure 3 (c). ON/OFF control by optocoupler.

Adjustment

Adjustment of output voltage of a power supply unit within the range of at least $\pm 5\%$ can be done by connecting "ADJ" output (if available) through "-OUT" output to increase output voltage, or through "+OUT" output to decrease the output voltage.

In case of using variable resistor Rvar and outside resistors (R1, R2) it is possible to fulfill the adjustment both to increase and decrease the output voltage.

If you need to control the output voltage of a power supply unit by a signal from external source of current or voltage, e.g. in micro-controller automated control systems using DAC, the external current or voltage signal should be supplied to the adjustment output relating to "-OUT" output, as shown in the drawings (e) and (d).

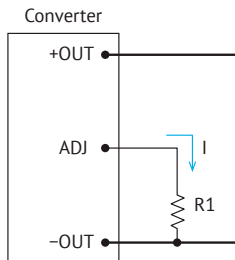

Figure 4 (a). Output voltage increase.

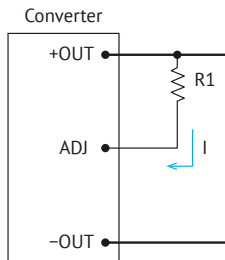

Figure 4 (b). Output voltage decrease.

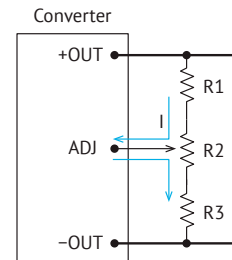

Figure 4 (c). Adjustment by resistive divider.

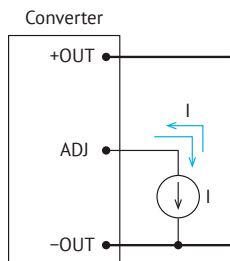

Figure 4 (e). Adjustment by current source.

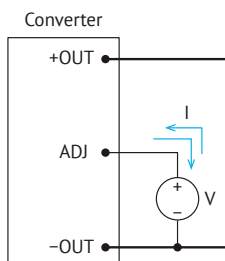

Figure 4 (d). Adjustment by voltage source.

Service functions (cont.)

Output voltage VS resistor rating

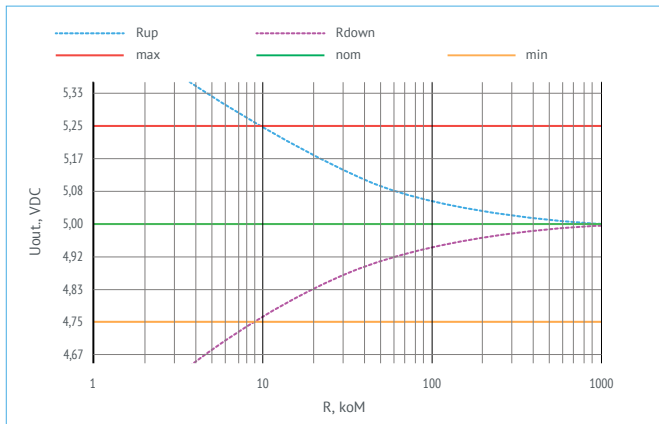

Figure 5 (a). Current and voltage values for adjustment of $U_{out}=5$ VDC.

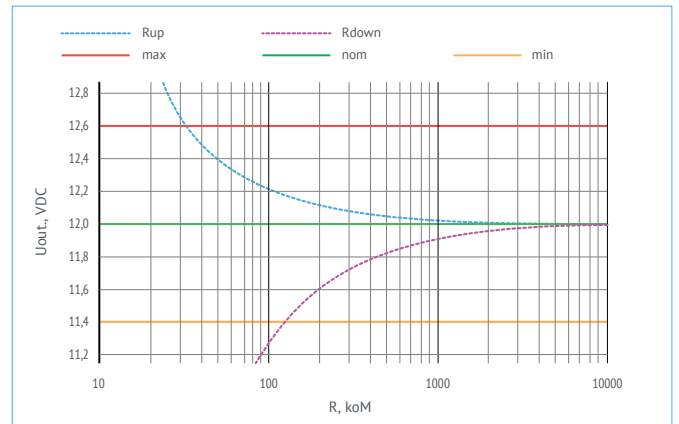

Figure 5 (b). Current and voltage values for adjustment of $U_{out}=12$ VDC.

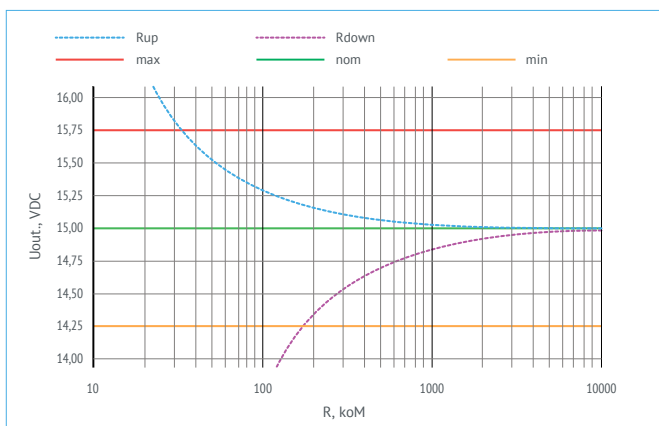

Figure 5 (c). Current and voltage values for adjustment of $U_{out}=15$ VDC.

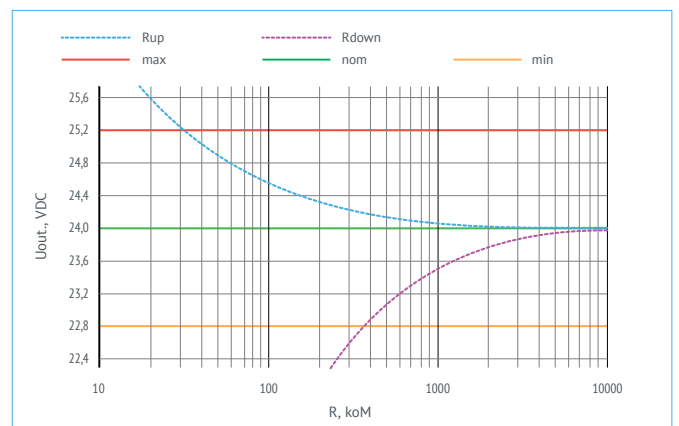

Figure 5 (d). Current and voltage values for adjustment of $U_{out}=24$ VDC.

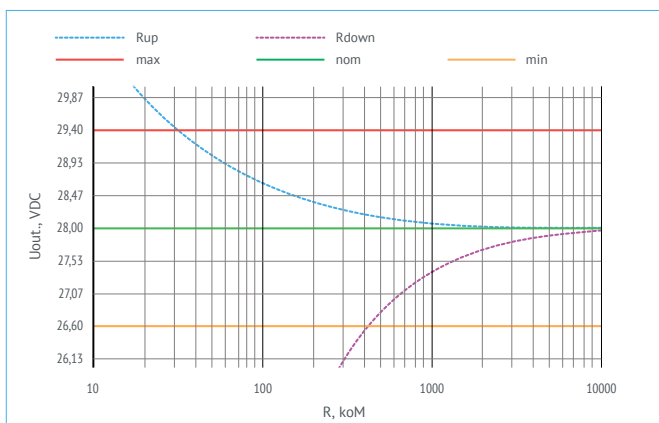

Figure 5 (e). Current and voltage values for adjustment of $U_{out}=28$ VDC.

Test reports

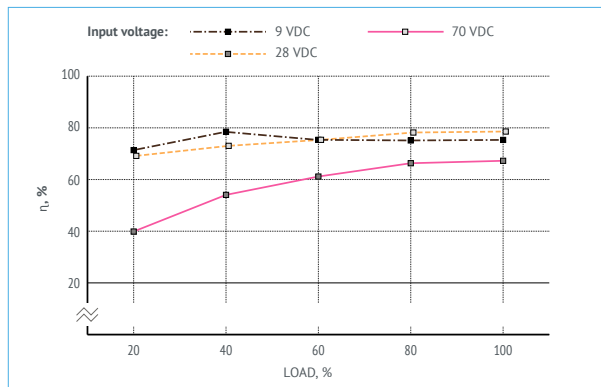

Figure. 6 (a). Efficiency of VDV8-1E12.

Oscillograph charts

Testing conditions $U_{in}=28$ VDC, $I_{out}=1,6$ A, $T_{amb}=25^{\circ}\text{C}$, $U_{out}=5$ VDC, $C_{out}=250$ μF

The database of regulated parameters of the manufactured products is available. Pls. contact your personal manager or customer support service to get necessary information.

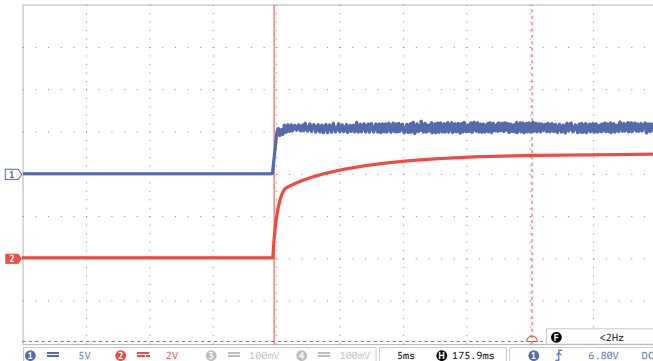

Figure 7 (a). Oscillograph chart of setting output voltage after supplying remote control signal to ON-output.

Ray 1 (blue) – voltage at ON-output. Scale 5 V/div.

Ray 2 (red) – output voltage. Scale 2 V/div.

Time scale $t=5$ ms/div.

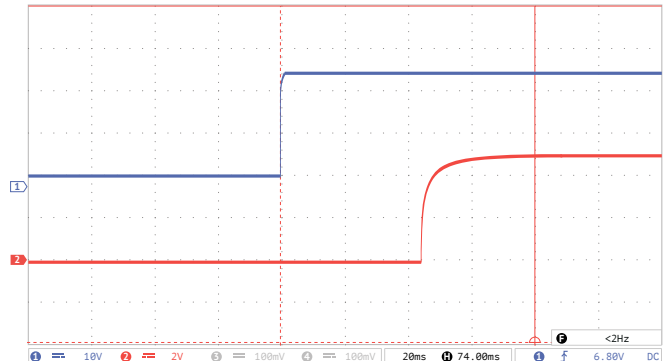

Figure 7 (b). Oscillograph chart of output voltage after supplying the input voltage.

Ray 1 (blue) – input voltage. Scale 10 V/div.

Ray 2 (red) – output voltage. Scale 2 V/div.

Time scale $t=20$ ms/div.

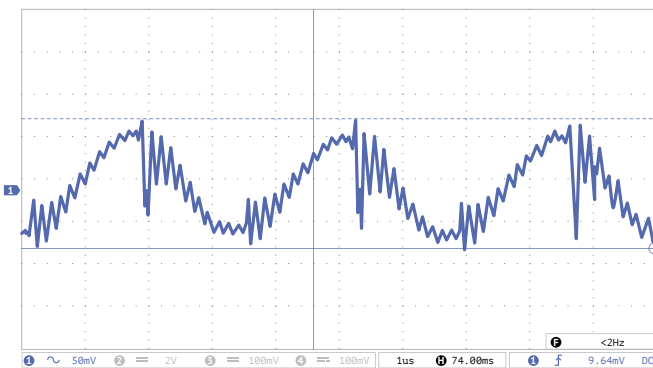

Figure 7 (c). Oscillograph chart of output voltage ripple.

Ray 1 (blue) – ripple of output voltage. Scale 50 mV/div.

Time scale 1 μs /div.

Measuring technique: see Electrical Test Screen.

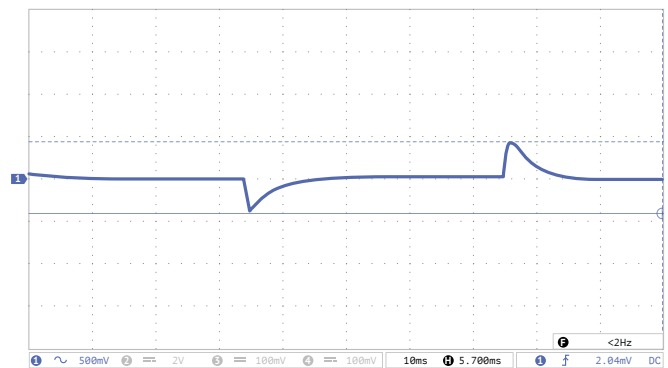

Figure 7 (d). Oscillograph chart of voltage transient deviation during load "drop/rise".

Ray 1 (blue) - output voltage. Scale 500 mV/div.

Time scale $t=10$ ms/div.

Modes:

- "drop" output current variation (10...100%) I_{nom} ;
- "rise" output current variation (10...100%) I_{nom} ;
- front time 500 μs .

Noise spectrogram

Testing according to MIL-STD-461F CE102. (Tcase=25°C, Vin.=+12 V, full load, unless otherwise specified)

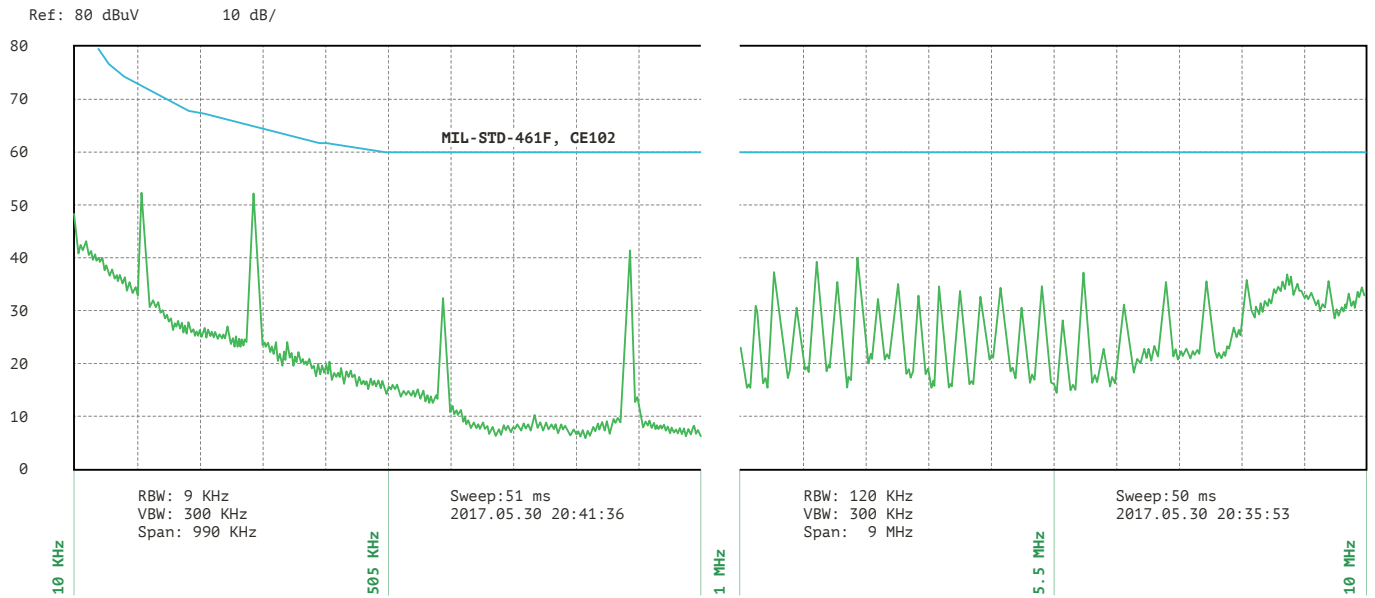

Figure 8. Spectrogram of VDV8 with typical connection diagram.

Outline dimensions

Models packed in reinforced case with flanges

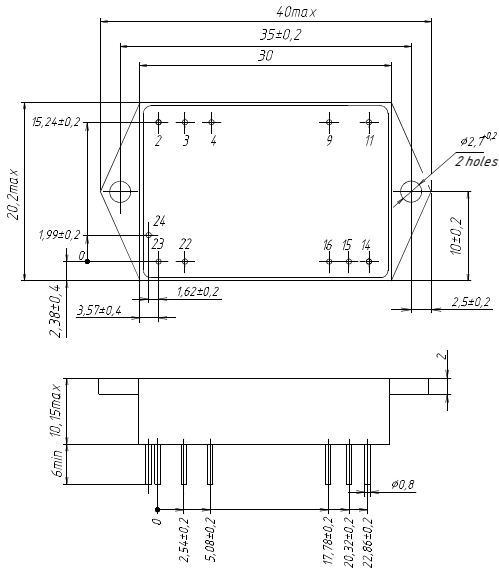

Figure 9 (a). Single-output models.

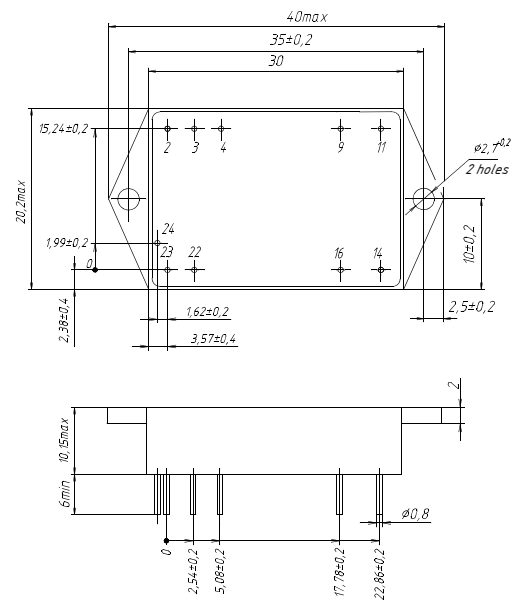

Figure 9 (b). Dual-output models.

Pin out

Pin #	2, 3	4	9	11	14	15	16	22, 23	24
Single channel	-IN	ON	NOT USE	NOT USE	+OUT	TRIM	-OUT	+IN	CASE
Dual channel	-IN	ON	+OUT2	-OUT2	+OUT1	-	-OUT1	+IN	CASE

Heatsink

Part number	Ribs configuration	Dimensions A×B×H×D, mm	Area, cm ²	Weight, g
752694.001	Cross	40×20×14×2	74	14
752694.002	Longitudinal	40×20×14×2	74	14

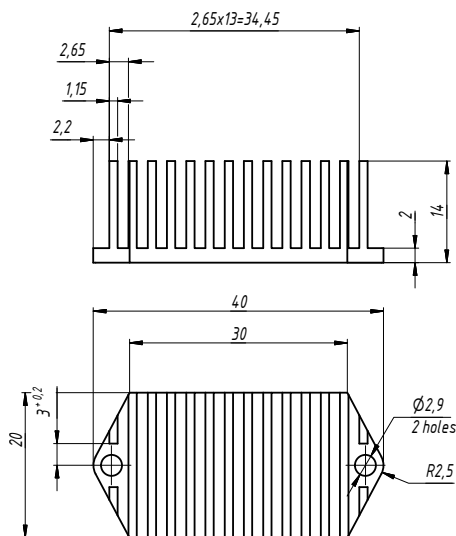

Figure 10 (a). 752694.001.

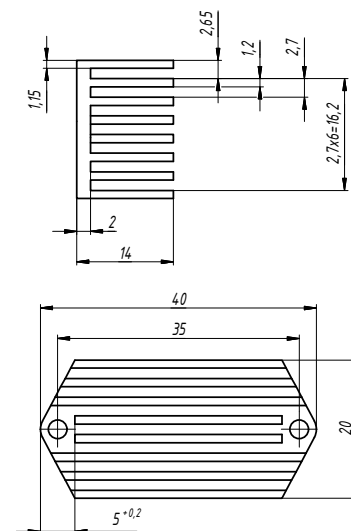

Figure 10 (b). 752694.002.

voltbricks

www.voltbricks.com info@voltbricks.com

VOLTBRICKS PTE. LTD.

105 Cecil street

#15-01 The OCTAGONE

Singapore 069534

+65 6950 0011

Manufacturer of reliable DC/DC converters and power supply systems

This datasheet is valid for the following units: VDV3-1E05; VDV3-1E09; VDV3-1E12; VDV3-1E15; VDV3-1E24; VDV3-1E28; VDV3-2E0505; VDV3-2E0909; VDV3-2E1212; VDV3-2E1515; VDV3-2E2424; VDV3-2E2828; VDV5-1E05; VDV5-1E09; VDV5-1E12; VDV5-1E15; VDV5-1E24; VDV5-1E28; VDV5-2E0505; VDV5-2E0909; VDV5-2E1212; VDV5-2E1515; VDV5-2E2424; VDV5-2E2828; VDV8-1E05; VDV8-1E09; VDV8-1E12; VDV8-1E15; VDV8-1E24; VDV8-1E28; VDV8-2E0505; VDV8-2E0909; VDV8-2E1212; VDV8-2E1515; VDV8-2E2424; VDV8-2E2828.